

**Models No.** ▶ MT240

**Description** ▶ Portable Cut-Off 355mm (14")

## CONCEPTION AND MAIN APPLICATIONS

The above product has been added to MAKTEC series tool.

Its features are as follows.

- \* Less expensive but service life is as long as existing MAKITA models.
- \* Easy-to-repair construction



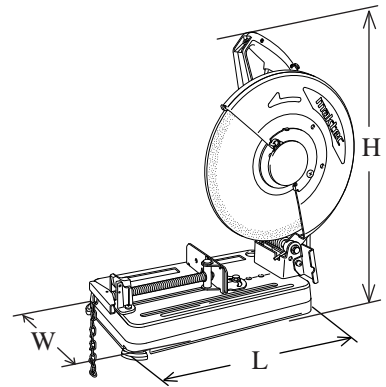

Dimensions : mm ( " )	
Length ( L )	500 (19-3/4)
Height ( H )	620 (24-3/8)
Width ( W )	280 (11)



## ► Specification

Voltage (V)	Current (A)	Cycle (Hz)	Continuous Rating (W)		Max. Output(W)
			Input	Output	
110	15.0	50 / 60	1,650	900	2,500
120	15.0	60	—	900	2,500
220	9.6	50 / 60	2,000	1,400	3,000
230	9.2	50 / 60	2,000	1,400	3,000
240	8.8	50 / 60	2,000	1,400	3,000

<b>No load speed : min-1= rpm.</b>	3,800	
<b>Wheel size : mm ( " )</b>	<b>Diameter</b>	355 (14)
	<b>Arbor</b>	25.4 (1)
	<b>Thickness</b>	3 (1/8)
<b>Net weight : Kg ( lbs )</b>	15.9 (35.1) including abrasive cut off wheel	
<b>Cord length : m (ft )</b>	2.0 (6.6) for Australia	
	2.5 (8.2) for other countries	

Capacity : mm ( " )		
Miter Angle	0°	45°
	115 (4-1/2)	115 (4-1/2)
	W : 194 (7-5/8) H : 102 (4) W : 233 (9-1/8) H : 70 (2-3/4)	H : 115 (4-1/2) W : 103 (4-1/16)
	L : 119 (4-11/16)	L : 106 (4-3/16)
	S : 137 (5-3/8) T : 10 (3/8)	S : 100 (3-15/16) T : 10 (3/8)

## ► Standard equipment

- \* Socket wrench 17 ..... 1 pc.
- \* Switch button for spare ..... 1 pc. (for the countries which require "Lock off switch")
- \* Abrasive cut off wheel ..... 1 pc.

< Note > The standard equipment for the tool shown may differ from country to country.

## ► Features and benefits

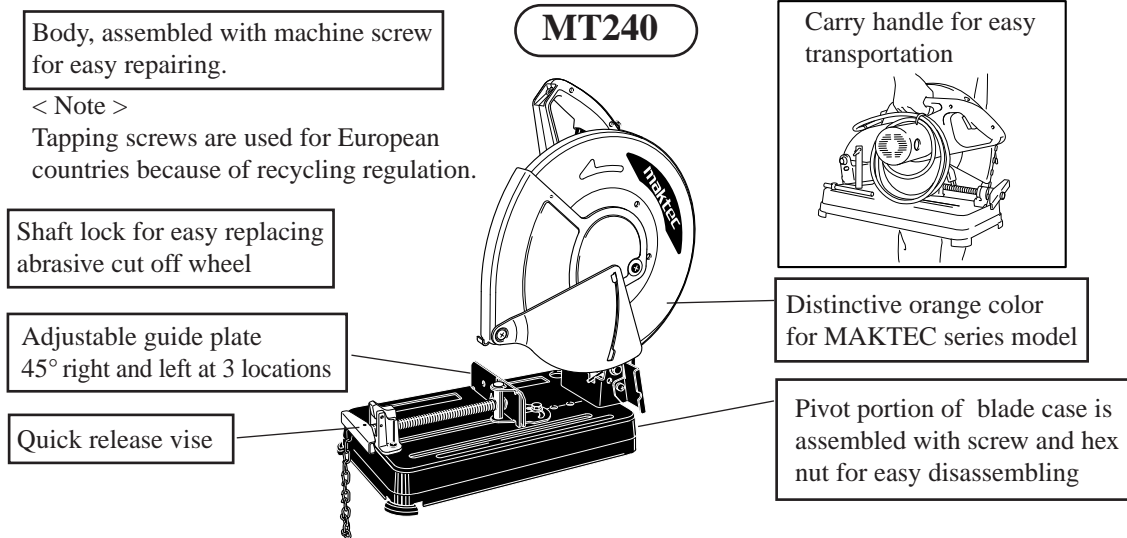

The combinations of safety guard with switch are as follows, which differ from country to country.

For North America	For Malaysia, Singapore	For Australia, Europe	For Other countries
w/ single safety guard + Lock-OFF switch	w/ single safety guard + Lock-ON switch	w/ double safety guard + Lock-OFF switch	w/o safety guard + Lock-ON switch

## ► Comparison of products

Model No.		MAKTEC	MAKITA	Competitor A	Competitor B	Competitor C
		MT240	2414NB	Model A	Model B	Model C
Specifications	Diameter	355 (14)	355 (14)	355 (14)	355 (14)	355 (14)
	Arbor	25.4 (1)	25.4 (1)	25.4 (1)	25.4 (1)	25.4 (1)
	Thickness	3 (1/8)	3 (1/8)	3 (1/8)	3 (1/8)	3 (1/8)
Power input : W		2,000	2,000	2,300	2,300	2,000
Rated amperage for N. America		15 A	15 A	—	—	—
No load speed : min <sup>-1</sup> = rpm.		3,800	3,800	3,500	3,900	3,800
Capacity : mm ( " )		115 (4-1/2)	115 (4-1/2)	120 (4-3/4)	120 (4-3/4)	120 (4-3/4)
		194 (7-5/8)	194 (7-5/8)	120 (4-3/4)	120 (4-3/4)	105 (4-1/8)
		102 (4) 233 (9-1/8) 70 (2-3/4)	102 (4) 233 (9-1/8) 70 (2-3/4)	120 (4-3/4)	130 (5-1/8)	105 (4-1/8)
Shaft lock		Yes	Yes	Yes	Yes	Yes
Quick release vise		Yes	Yes	Yes	Yes	Yes
Protection from electric shock		double insulation	double insulation	grounding	grounding	grounding
Cord length : m (ft)		2.5 (8.2)	2.5 (8.2)	2.0 (6.6)	3.7 (12.2)	2.0 (6.6)
Net weight w/ wheel : kg (lbs)		15.9 (35.1)	16.2 (35.7)	19.3 (42.6)	17.0 (37.5)	17.0 (37.5)
Dimensions	Length : mm ( " )	500 (19-3/4)	500 (19-3/4)	500 (19-3/4)	450 (17-3/4)	470 (18-1/2)
	Width : mm ( " )	280 (11)	280 (11)	260 (10-1/4)	250 (9-7/8)	280 (11)
	Height : mm ( " )	620 (24-3/8)	600 (23-5/8)	640 (25-1/4)	650 (25-1/2)	660 (26)

► **Comparison of products**  
**Comparison of cutting speed**

Numbers in chart below are relative values when setting BOSCH GCO14D's capacity as 100.

Form and size of material for test

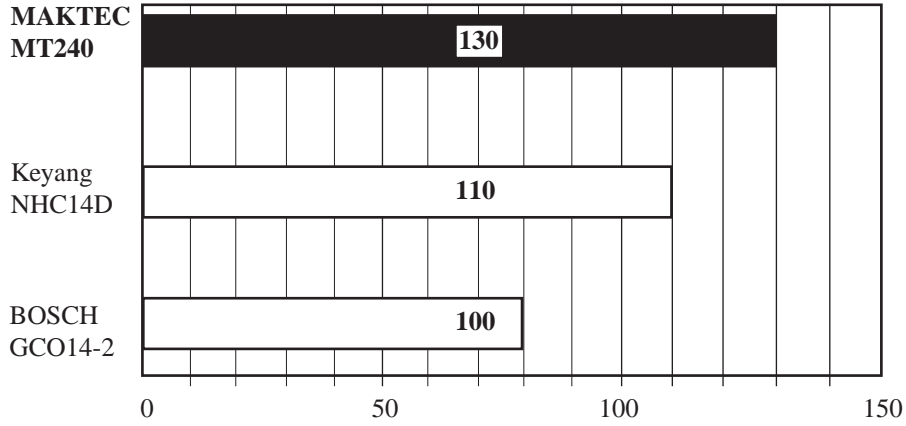
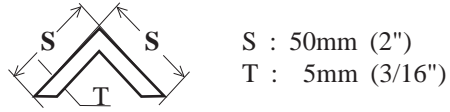

Form and size of material for test

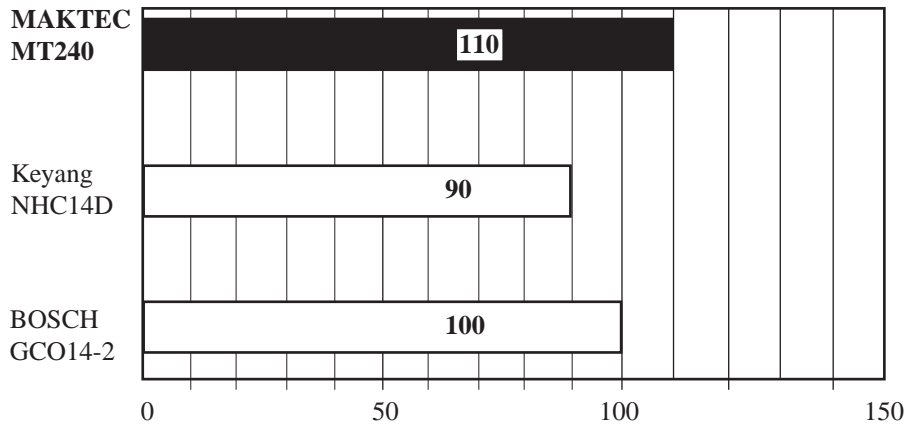
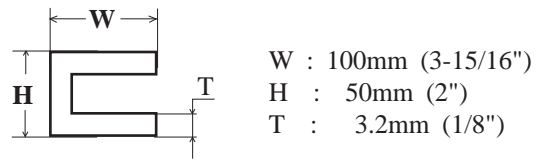

## < 1 > Lubrication

Apply MAKITA grease N. No.1 to the following portions marked with black triangle to protect parts and product from unusual abrasion. See Fig. 1.

20. Helical gear 49

57. Gear room of gear housing : approx 25g (0.9 oz.)

77. Pipe 20-128 : approx. 0.1g (0.01 oz.)

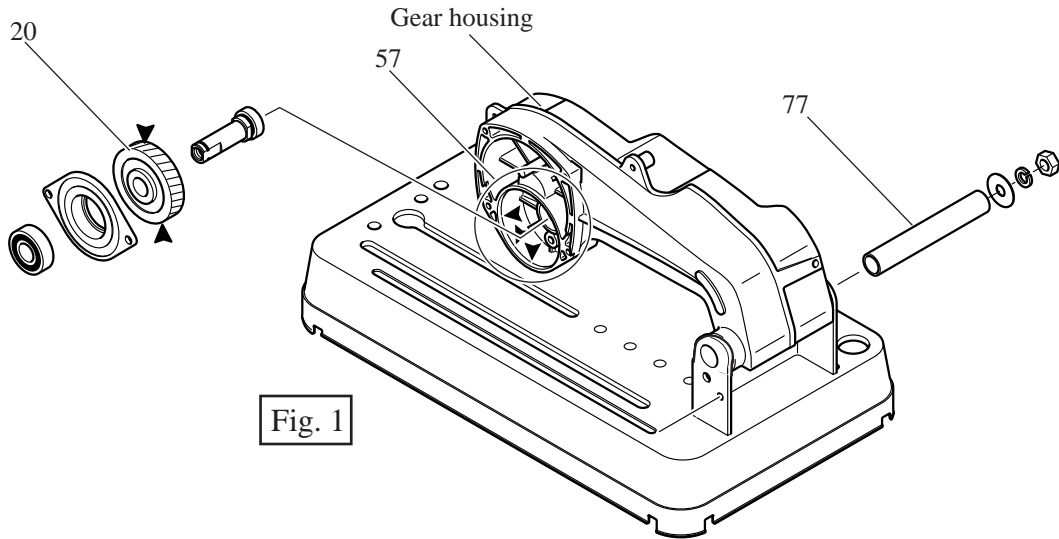

Fig. 1

## < 2 > Replacing armature

- (1) Remove carbon brushes. Remove handle L by unscrewing 3 pcs. of pan head screws M4x25 and 4 pcs. of pan head screws M5x40. See Fig. 2.
- (2) Remove motor housing by unscrewing 4 pcs. of pan head screws M5x40. Then, armature can be removed. See Fig. 3.

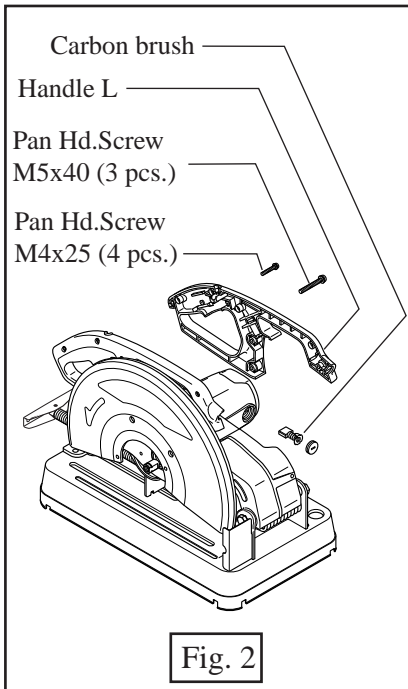

Fig. 2

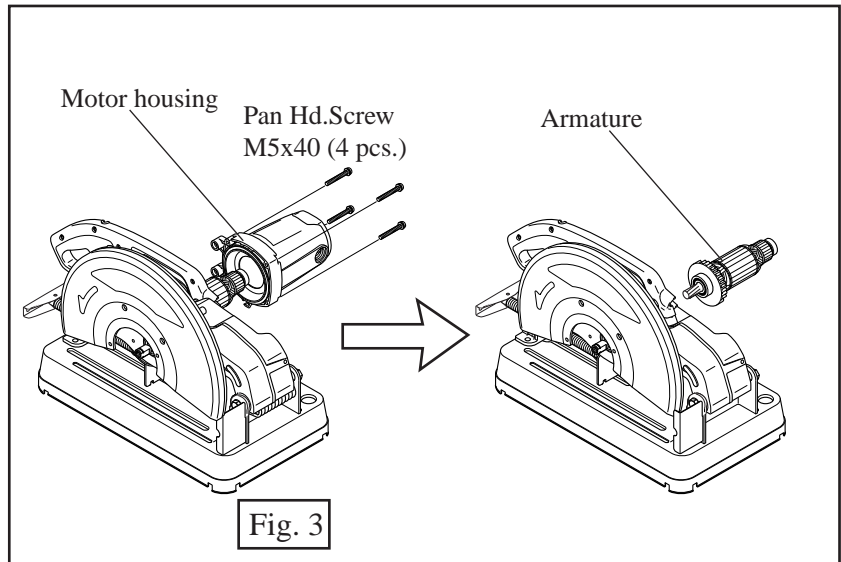
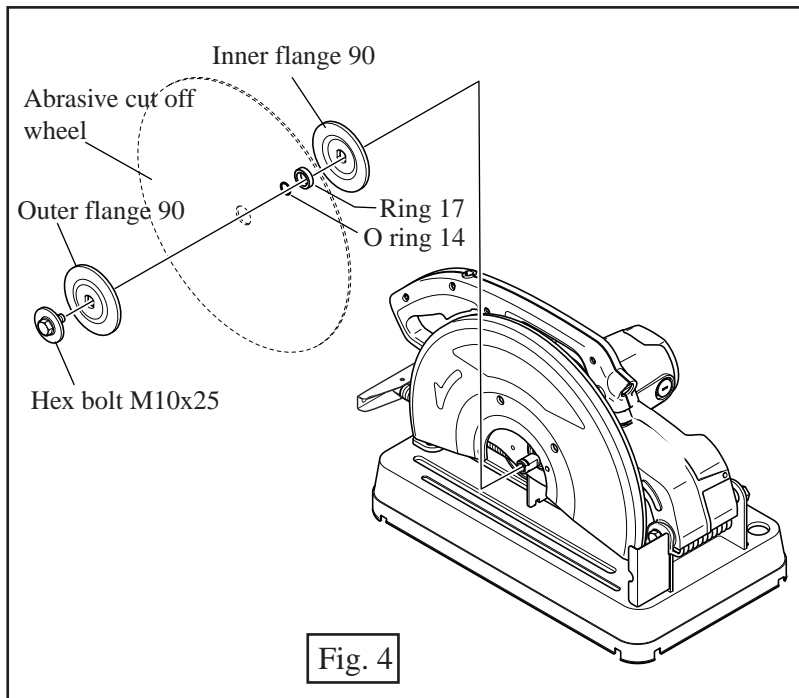

Fig. 3

- (3) After mounting new armature to gear housing, secure motor housing with 4 pcs. of pan head screws M5x40 as illustrated in Fig. 3.
- (4) Secure handle L with 4 pcs. of pan head screws M4x25 and 3 pcs. of pan head screws M5x40. And mount carbon brush. See Fig. 2.

< 3 > Disassembling gear section

( 1 ) Take off hex bolt M10x25, outer flange 90, abrasive cut off wheel, O ring 14, ring 17 and inner flange 90 from spindle. See Fig. 4.



( 2 ) Unscrew 4 pcs. of pan head screws M5x20. Then, safety cover and gear section can be removed from the machine. See Fig. 5.

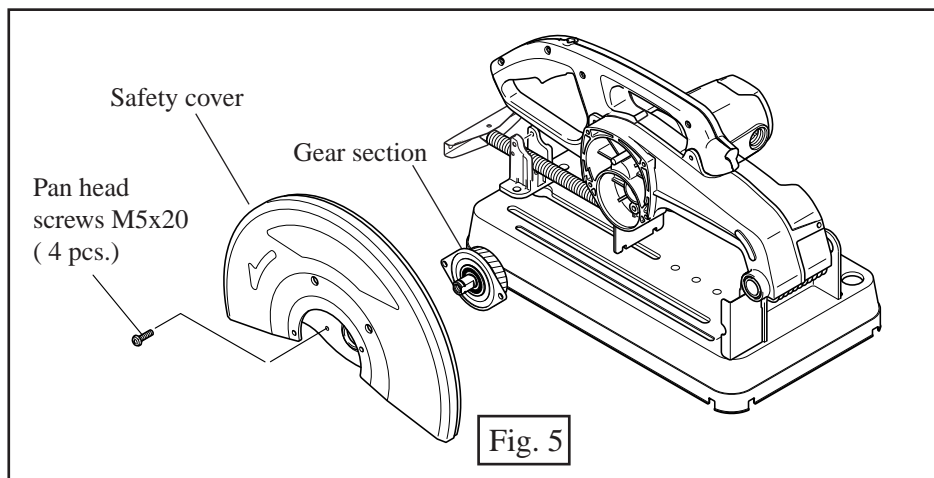

( 3 ) Remove ball bearing 6000ZZ with No.1R269 "Bearing extractor" as illustrated in Fig. 6.

( 4 ) Press spindle with arbor press. Then, helical gear 49 can be removed. See Fig. 7.

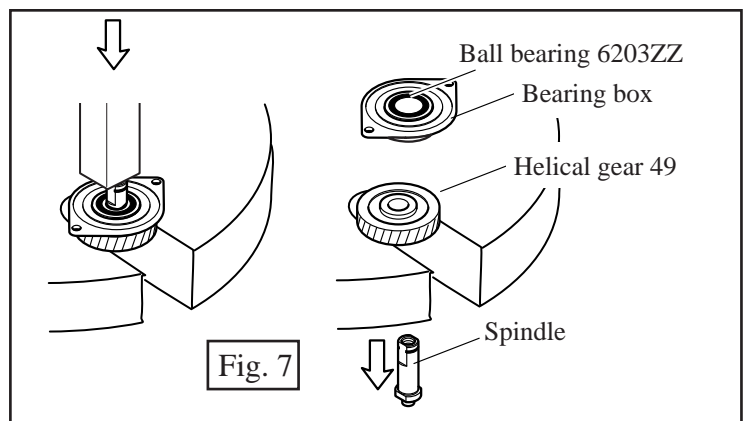
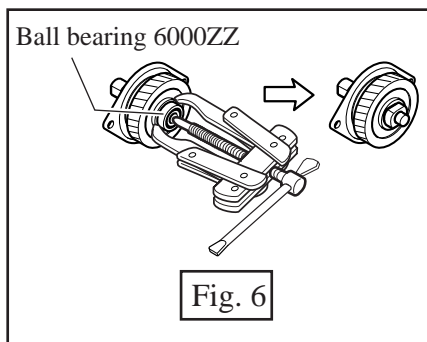

< 4 > Assembling gear section

- ( 1 ) Put helical gear 49 on the bearing setting plate and mount spindle to the helical gear 49 by pressing with arbor press. See Fig. 8.
- ( 2 ) Put bearing box on the bearing setting plate and mount the helical gear 49 to the bearing box by pressing with arbor press. And then, mount ball bearing 6000ZZ to spindle. See Fig. 9.

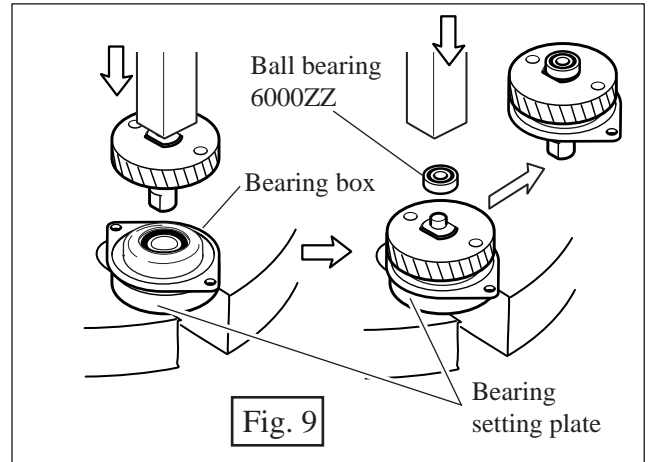
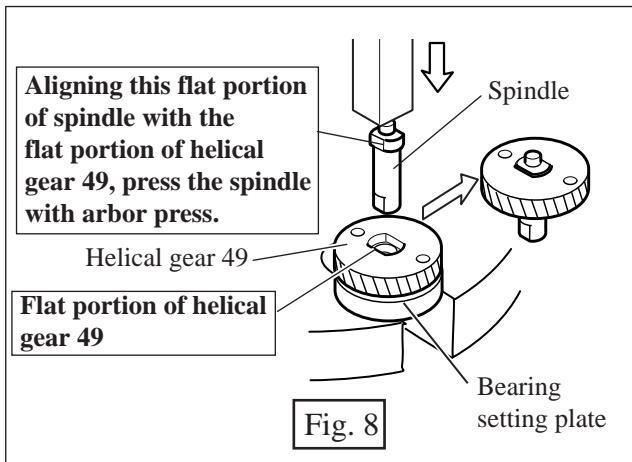

< 5 > Removing vise section

- ( 1 ) Unscrew 2 pcs. of pan head screws M8x30. Then, screw guide can slide on base. See Fig. 10.
- ( 2 ) Slide the vise section in the direction of arrow. Align the shoulder pin with the assembling hole of base. See Fig. 11.
- ( 3 ) Remove vise section from the assembling hole. See Fig. 12.

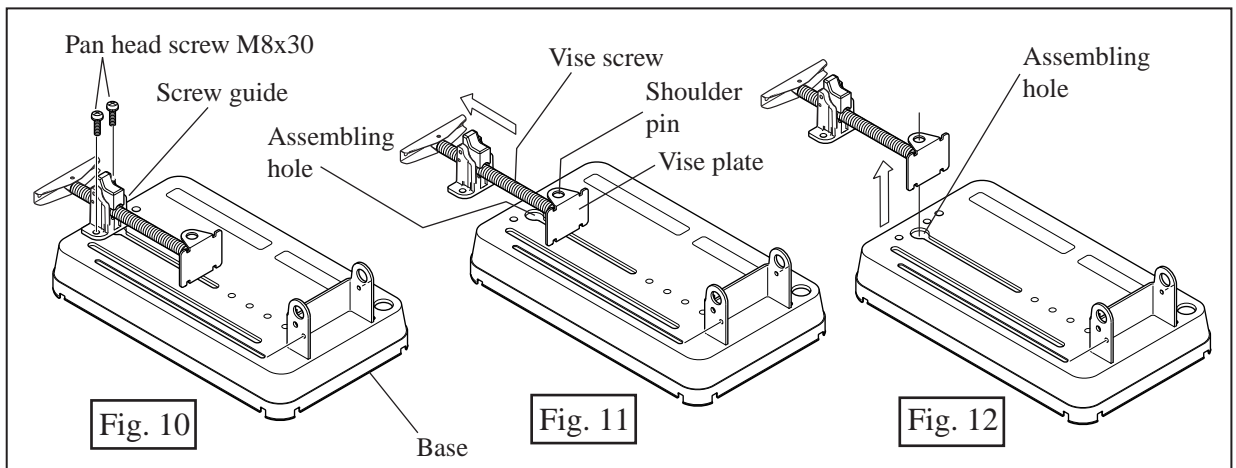

< 6 > Removing Motor unit from base

- ( 1 ) Secure the motor unit with chain as illustrated in Fig. 13.
- ( 2 ) Remove spark guard from base, and unscrew hex socket head bolt M6x12 and hex nut M6. See Fig. 14.

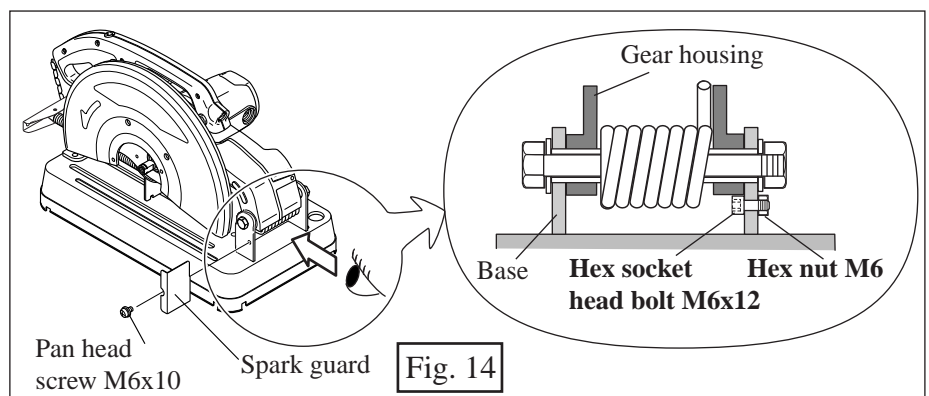
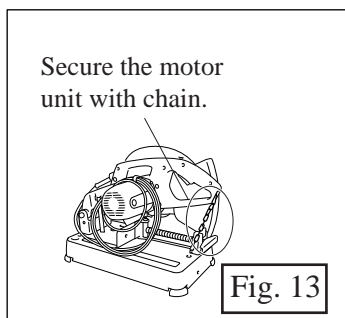



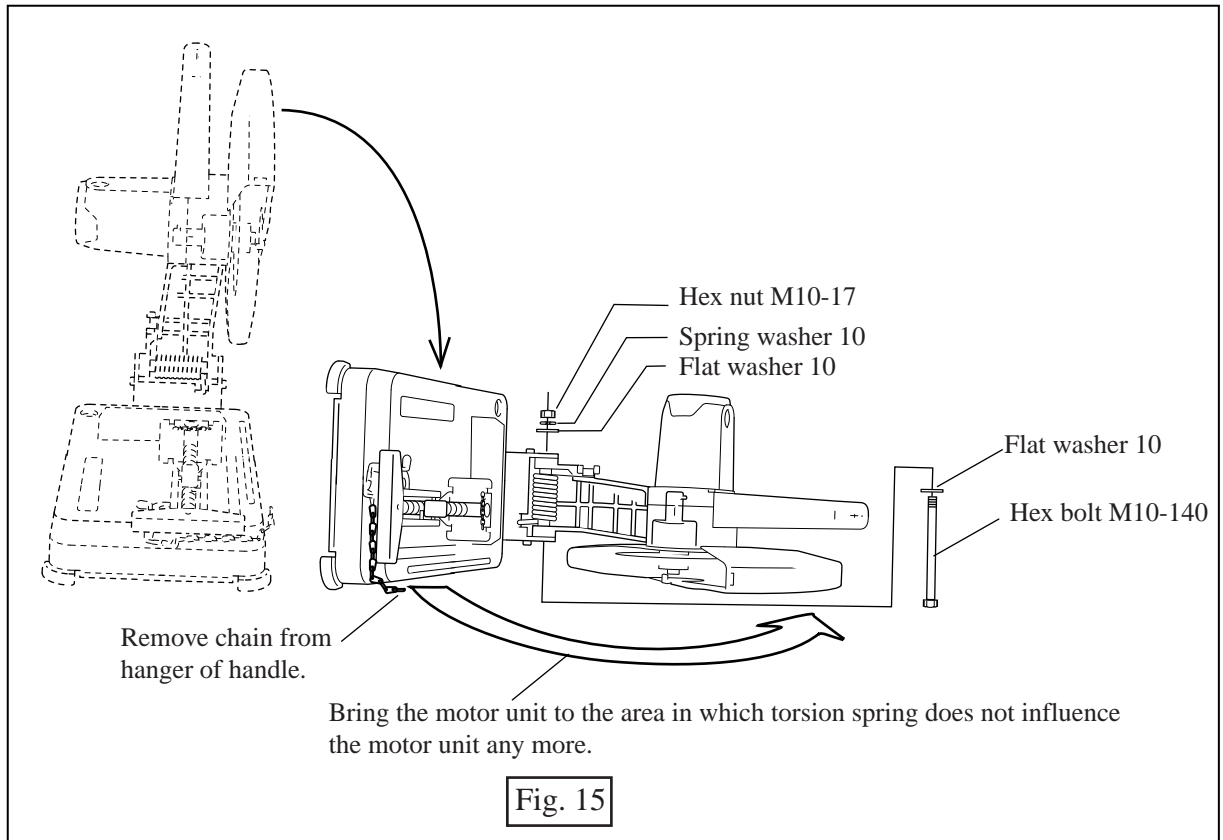

- ( 3 ) Lay the product. Remove chain with which you secured the motor unit in Fig. 13, from hanger of handle. See Fig. 15.
- ( 4 ) Bring the motor unit to the area in which torsion spring does not influence the motor unit any more. See Fig. 15.
- ( 5 ) Unscrew Hex nut M10-17 and remove spring washer 10, flat washer 10, hex bolt M10-140 and another flat washer 10. See Fig. 15.

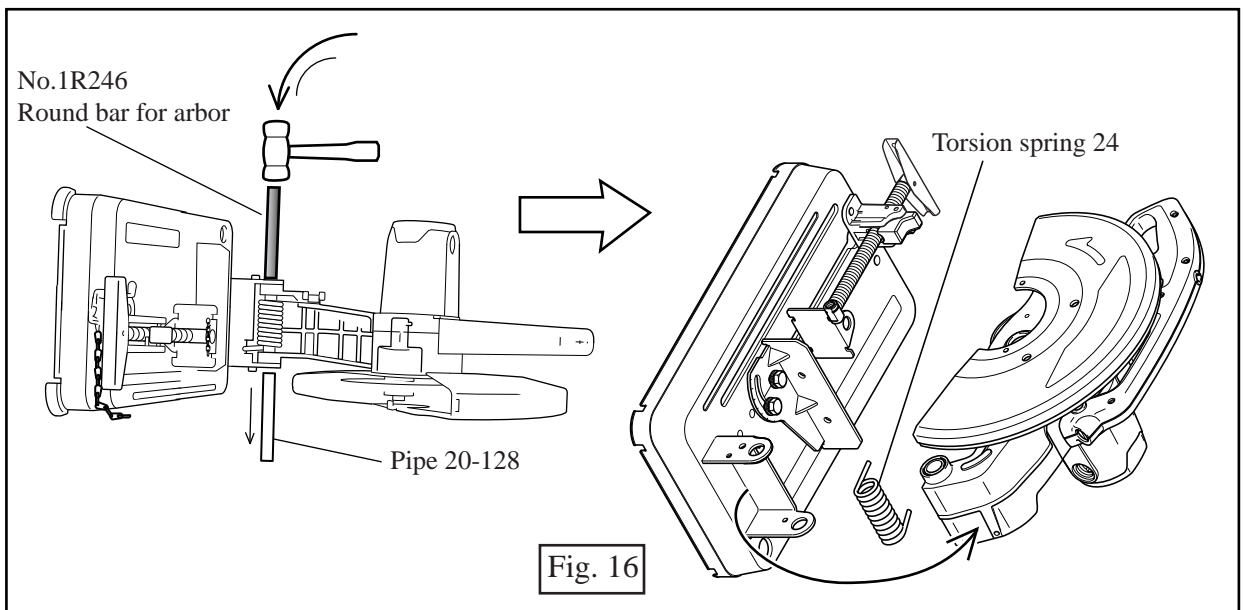

- ( 6 ) Remove pipe 20-128 by striking with hammer slightly. Then the motor unit can be separated from base. See Fig. 16.



Color index of lead wires	
Black	
White	
Blue	
Brown	

The product to be supplied to the countries where terminal block is required.

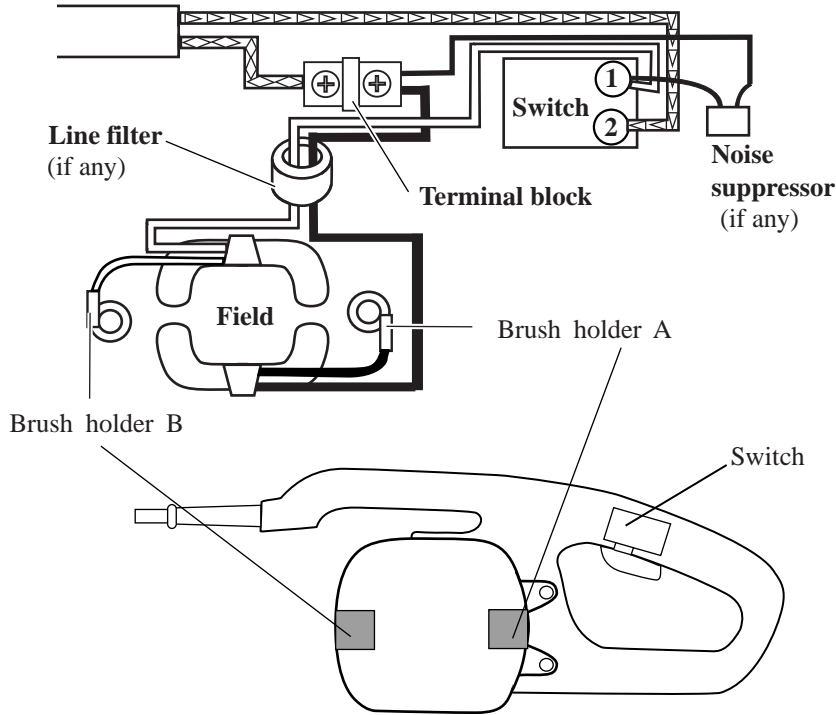

The product to be supplied to the countries where terminal block is not required.

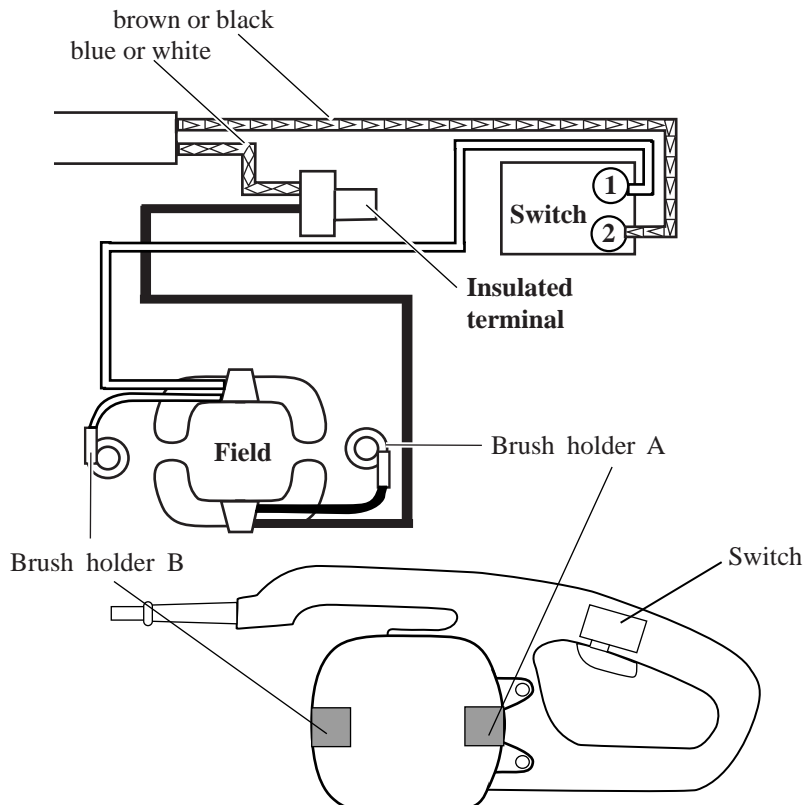



**Wiring in motor housing**

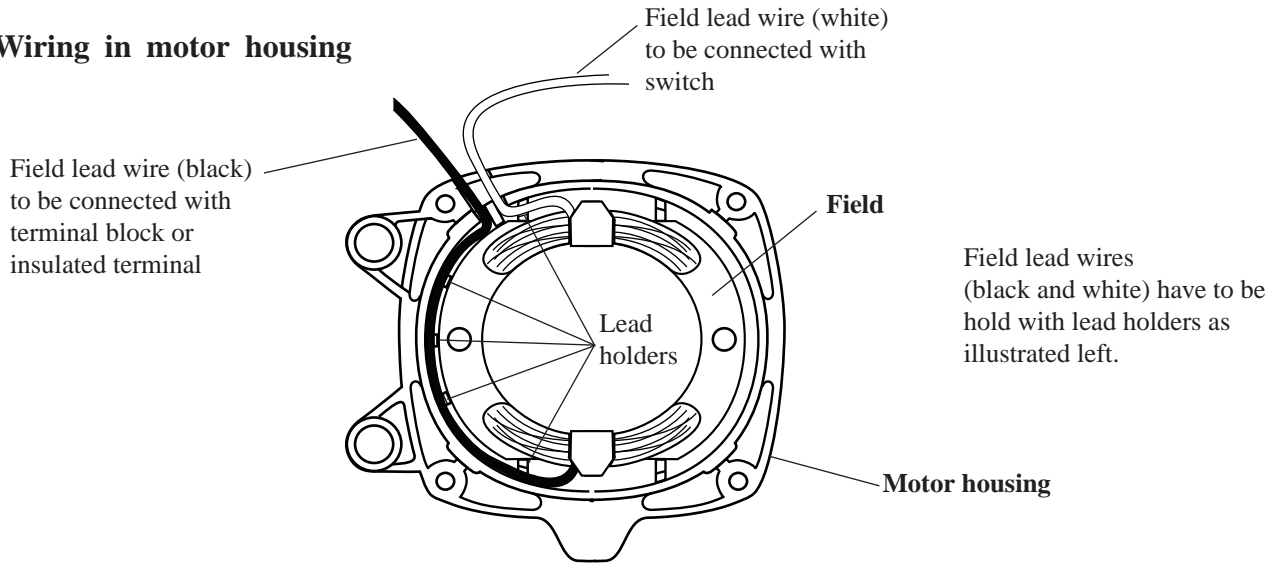

**Wiring in handle R**

